



www.tezsan.com

BALL-SCREW PRESS BRAKE

Compact Bending Solutions with High Efficiency







 www.tezsan.com



BALL-SCREW PRESS BRAKE

Single / Dual Lenze Drive Technology

-  Energy saving up to 50%
-  Higher Productivity
-  Low maintenance cost
-  High accuracy positioning and repeatability
-  Light and compact design

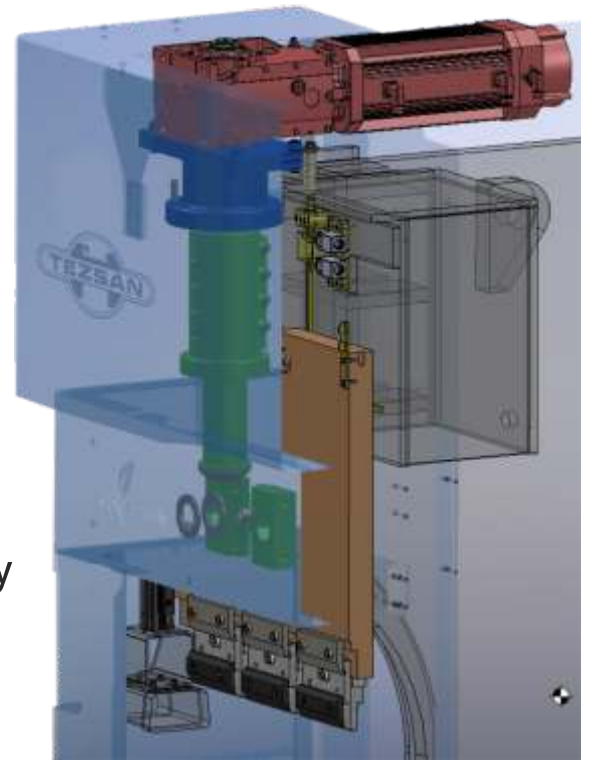

Control Unit

ESA S 640 Control Unit

- 15" color touch screen
- Automatic bend sequence
- Easy programmable 2D graphic display.
- Multiple language options
- 2D Simulation
- Remote access

ESA S 675 3D Control Unit (Optional)
DELEM 66T Control Unit (Optional)
DELEM 69T 3D Control Unit (Optional)



Work Table (Optional)

Foldable and height adjustable ergonomic working table makes bending easier and comfortable.



Tools Clamping

Euro Type punch and die clamping
Wila mechanical and hydraulic clamping (Optional)





DDS



100% ELECTRICAL BALL-SCREW PRESS BRAKE

■ Back Gauge

- 2 axis back gauge handles complex parts with ease. (5 axis optional - Z1, Z2 and X-Prime with ESA675 controller)
- High speed movement combined with high accuracy drives ensures the back gauge is positioned quickly and precisely every time for the operator.

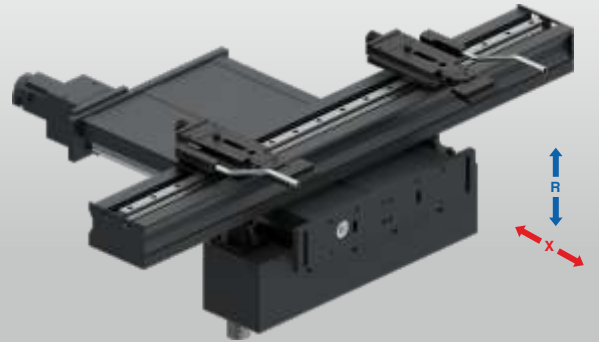

■ Safety System

Laser finger protection system with safety PLC (Optional).



■ Other Advantages

- Electrical cabinet cooler
- Easier box bending with larger daylight
- Quick installation and transportation

■ Body Frame

Rigid monoblock body for high precision
Light and compact frame designs
Ergonomic working for operator

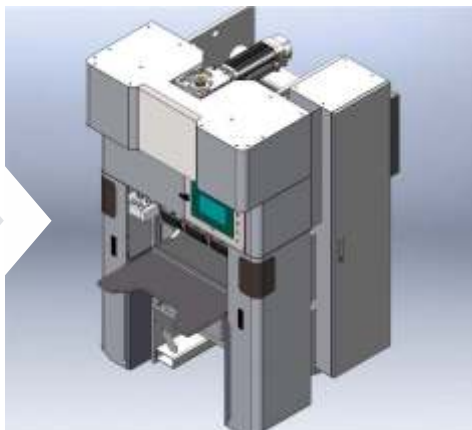

NO | HYDRAULIC OIL
HYDRAULIC FILTER
HYDRAULIC SEALS
VALVES
CYLINDERS
DWELL TIMES

Technical Data

B-Servo 4013

B-Servo 2090

Bending Length (B) (mm)	1300	900
Bending Capacity (ton)	40	20
Daylight (Q) (mm)	375	375
Maximum Stroke (mm)	150	150
Y Axis (Approaching/Bending/Return) Velocity (mm/sec)	150/20/150	150/20/150
Motor Power (kW)	2x3,8	3,8
Length (A) (mm)	1880	1280
Width (C) (mm)	2435	1760
Height (D) (mm)	2320	2190
Weight (Appr.) (kgs)	3400	2000

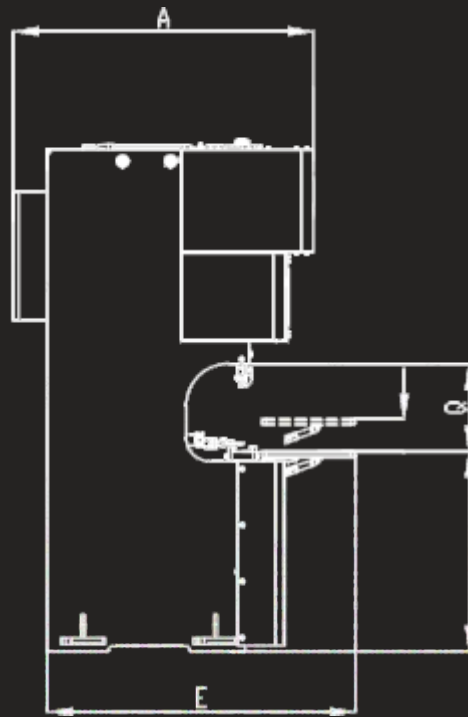
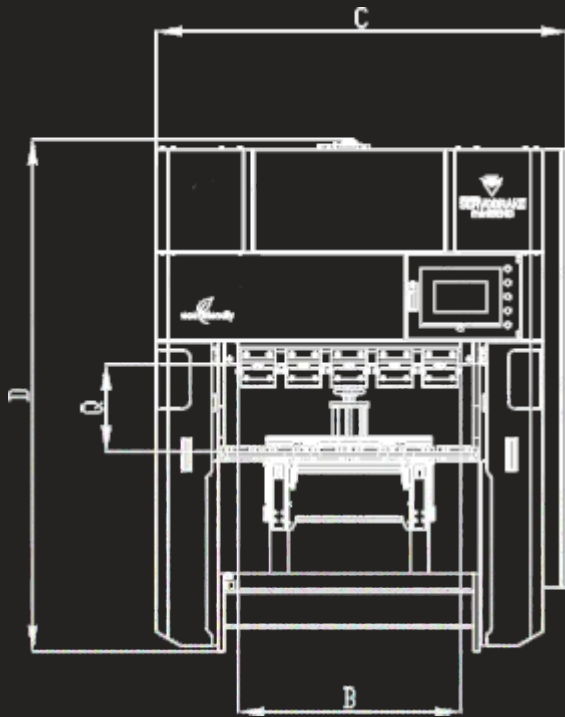

+90 352 321 13 50
+90 352 321 13 53
info@tezsansan.com
www.tezsansan.com